

# Product data sheet

## Characteristics

# 9070TF100D1

Transformer, Type TF, industrial control, 1000 VA, 240/480 VAC primary / 120 VAC secondary, 1 phase, 50/60 Hz, 115 °C rise



Product availability: Stock - Normally stocked in distribution facility

Price\*: 201.00 USD



### Main

Product or component type	Industrial Control Transformer
Rated power in VA	100 VA
Primary voltage	220 x 440 V 230 x 460 V 240 x 480 V
Secondary voltage	115 V 120 V 110 V
Range of product	TF

### Complementary

Phase	1 phase
Rated power in VA	100 VA
Primary voltage	220 x 440 V 110 V 230 x 460 V 115 V 240 x 480 V 120 V
Fuse type	0.41 x 1.50 in CC top
Temperature rise	55 °C
Electrical connection	Screw clamp terminals
Height	4.25 In (107.95 mm)
Width	3.38 In (85.85 mm)
Depth	3.34 In (84.84 mm)
Material	Copper winding
Product compatibility	FSC1

## Environment

Product certifications	UL listed file E61239 CSA file LR37055 guide 184-N-90
NEMA degree of protection	Not rated (open device)
Insulation temperature	221 °F (105 °C)

## Ordering and shipping details

Category	16202 - 9070 TF (NOT T) 50-200VA
Discount Schedule	CP8
GTIN	00785901904786
Nbr. of units in pkg.	1
Package weight(Lbs)	4.60 Lb(US) (2.087 kg)
Returnability	Yes
Country of origin	MX

## Packing Units

Unit Type of Package 1	PCE
Package 1 Height	6.40 In (16.256 cm)
Package 1 width	6.70 In (17.018 cm)
Package 1 Length	7.80 In (19.812 cm)

## Offer Sustainability

Sustainable offer status	Green Premium product
California proposition 65	WARNING: This product can expose you to chemicals including: Phenyl glycidyl ether, which is known to the State of California to cause cancer and birth defects or other reproductive harm. For more information go to <a href="http://www.P65Warnings.ca.gov">www.P65Warnings.ca.gov</a>
REACH Regulation	<a href="#">REACH Declaration</a>
EU RoHS Directive	Compliant <a href="#">EU RoHS Declaration</a>
Mercury free	Yes
RoHS exemption information	<a href="#">Yes</a>
China RoHS Regulation	<a href="#">China RoHS Declaration</a>
Environmental Disclosure	<a href="#">Product Environmental Profile</a>
PVC free	Yes

## Contractual warranty

Warranty	18 months
----------	-----------

Approximate Dimensions

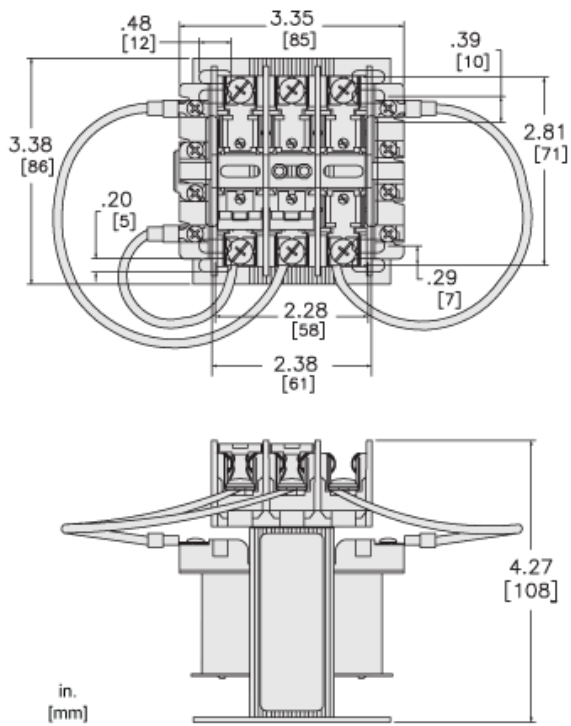

---

Connections and Wiring Diagrams

---

Product Life Status : <b>Commercialised</b>
---